



It is user **RESPONSIBILITY** to check that this manual (in PDF format) refers to product model and version that will be used.

In any case, regarding installation, use and maintenance, the paper-made manual given together with the product **TAKES PRIORITY.**

R.T.A. srl



# CSD SERIES STEPPING MOTOR DRIVES

## 1. GENERAL CHARACTERISTICS

		CSD 02 CSD 02.V	CSD 04 CSD 04.V	CSD 92	CSD 94
$V_{DC}$ with stabilized supply (+/- 5%)	(V)	from 22 to 50			
$V_{DC}$ with unstabilized supply (+/- 20%)	(V)	from 24 to 45			
$I_{NP}$ min	(A)	0.7	2.6	0.7	2.6
$I_{NP}$ max	(A)	2.4	4.4	2.4	4.4
Dimensions	(mm)	92 × 85 × 22	92 × 85 × 23	90 × 99 × 21	
Operating temperature		from + 5°C to + 45°C (see point 6.3)			

Table 1

### Terms definition in Table 1

- $V_{DC}$  Nominal value of DC voltage supply (range) at which the drive can operate.
- $I_{NP}$  Nominal phase current (peak value) which flow in each motor winding, measurable with motor turning at low speed. Automatic current reduction at motor standstill is 50% of value set using DIP-SWITCH.
- $I_{NP}$  min and max Minimum and maximum value of nominal phase current setting using DIP-SWITCH (see Tab. 2).

## 2. LOGIC INPUT AND OUTPUT SIGNALS (AM3 or C2 Connector, see Fig. 1, 2, 3, 4 and chap. 6.2)

- 2 - **CURRENT OFF INPUT:** When this signal is HIGH drive is active. When it is LOW drive is inhibited, thus motor current (and so holding torque) is turned to zero.
- 3 - **STEP INPUT:** Step is performed on HIGH to LOW transition of this signal. Suggested duty-cycle: 50%. Max. frequency: 60 KHz with square wave signal supplied from a logic output at 5 volt. With duty cycle different from 50%, STEP signal half period has to be longer than 8  $\mu$ sec.
- 4 - **DIRECTION INPUT:** With this signal HIGH motor rotation direction is opposite to the one obtained with input LOW. This signal has to be valid at least 100  $\mu$ s before STEP signal and has to stay in this state for at least 100  $\mu$ s after last step sent to the drive.
- 5 - **x4 INPUT:** When this input is active, the steps sent to STEP INPUT will be multiplied by 4. This input is active low when the drive is set in PULL-UP mode; is active high when the drive is set in PULL-DOWN mode (see Tab. 3). This input is never active if it is not used and open. (This logic input is available only with serial number greater than 3000).
- 7 - **DRIVER FAULT OUTPUT:** When drive is normally working, this output is SHORTED to GND; when drive is in no-working state, the output is OPEN. Drive automatically goes in no-working state when some protection is active and automatically recovers when the protection resets.
- 1 and 8 - **INTERNAL GND:** The terminals are internally connected between each others and to terminals 10 (the power supply common), 11 and 16. They can be used to connect the shield of logic signal cable (this is mandatory or useful depending on type of control system).

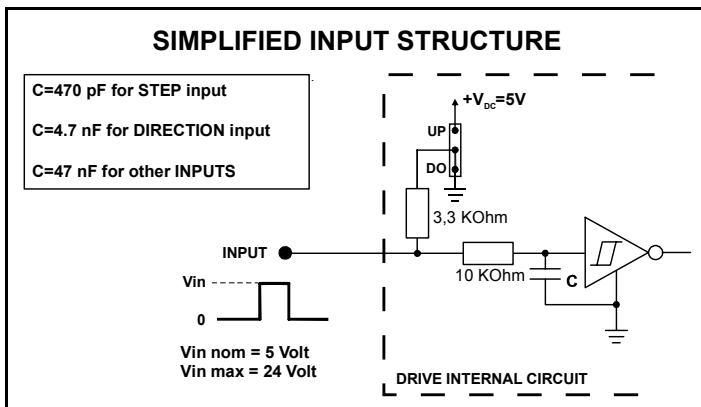

Fig. 1 a

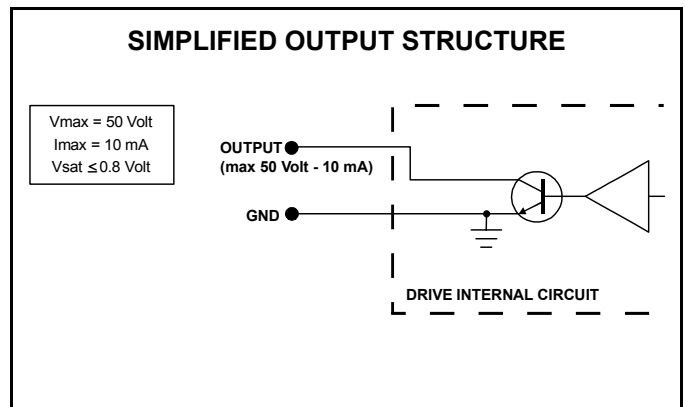

Fig. 1 b

### 3. POWER INPUTS AND OUTPUTS (AM1, AM2 or C1 Connectors; see Fig. 2 and 3)

- 9 - Power supply positive pole. (+  $V_{DC\ nom}$ ).
- 10 - Power supply negative pole. (-  $V_{DC\ nom}$ ).
- 11 - GROUND; connect to Protective Earth terminal (PE).
- 12 - Motor winding terminal **A**.
- 13 - Motor winding terminal **A-**.
- 14 - Motor winding terminal **B-**.
- 15 - Motor winding terminal **B**.
- 16 - Connection point for shield of motor shielded cable.

4. **MAIN SETTINGS (Dip switch and jumpers).** Main setting must be done by the user at the installation or replacement time, according to motor type and working condition. Wrong setting could damage drive or motor and cause a not correct work of the motor.

NOMINAL CURRENT $I_{NP}$ (A)				
	Dip 1	Dip 2	CSD 02 CSD 02.V CSD 92	CSD 04 CSD 04.V CSD 94
►	ON	ON	0.7	2.6
	ON	OFF	1.2	3.2
	OFF	ON	1.7	3.8
	OFF	OFF	2.4	4.4

Table 2

LOGIC INPUTS OPERATION MODE			
JUMPERS SETTING			
►	UP	ON	PULL-UP
	DOWN	OFF	
	UP	OFF	PULL-DOWN
	DOWN	ON	

Table 3

DAMPING		
	Dip 3	
	ON	ENABLED
►	OFF	NOT ENABLED

Table 4

RESOLUTION			
	Dip 5	Dip 6	STEPS FOR REV.
	ON	ON	3.200
►	ON	OFF	1.600
	OFF	ON	800
	OFF	OFF	400

Table 5

► = **Default settings**

#### Note about settings:

Dip 4 --> Reserved, set OFF ; FC Jumper --> Reserved, set OFF

- Damping can reduce the motor acoustical noise, but it causes a slight torque reduction in the mid speed range.
- Acoustical noise and vibrations can also be reduced setting the highest possible resolution, compatibly with the application needs.

## 5. LED DRIVE STATUS

- LED HV green:** **ON** = supply voltage value in working range.  
**OFF** = no supply voltage or supply voltage out of working range.
- LED FAU red:** **ON** = drive set in no working state by one of the following protection:
- a** - Max or Min voltage when LED HV is OFF
  - b** - Short circuit or wrong connection at motor output when LED HV is ON
  - c** - Thermal protection when LED HV is blinking (only with serial number greater than 3000)
- OFF** = drive active provided that LED HV is ON

## 6. APPLICATION NOTES

### 6.1. Electromagnetic interference.

Drive and all related connections are source of E.M. interference (conducted and radiated). In order to comply to 2004/108/CE and related standards (EN 61800-3), the installation has to be done in accordance with the schematics in Fig 2 and the following indications:

- Locate drives, power supply, transformer and related cables inside the same enclosure, which has to be hermetic to electromagnetic fields.
- Interpose a filter (CORCOM mod. 6VDK1) near the main supply entrance.
- Use only shielded cable (outside the enclosure) for connecting motor and drive.
- Connection made to Protective Earth terminal (PE), shown in Fig.2a e Fig. 2b, must be short and have the lowest possible inductance.
- Use a supply transformer with a metal shield between primary and secondary winding and connect this shield to PE.

### 6.2. Input logic signals.

- Rated nominal voltage of external logic: 5 volt ; minimum voltage: 3.5 volt ; maximum voltage: 24 volt
- Input low level < 1.0 volt ; Input high level > 2.4 volt

### 6.3. Forced cooling.

According to operating conditions (ambient temperature, current setting, duty-cycle) forced cooling could be necessary. This need occurs when, in the worst case of the operating conditions the drive heatsink temperature is greater than 65 - 70 °C .

### 6.4. Switching power supply.

It is possible to use a switching power supply instead of a traditional power supply indicated in Fig. 2a and Fig. 2b, provided that you have a capacitor of at least 1000  $\mu$ F on the output line of power supply. This capacitor should be located at a distance not greater than 1 - 2 meter from Vdc input of the drive. The purposes of the capacitor are:

- To feed the high frequency current pulses required by the drive chopper system.
- To absorb the reverse energy generated by motor during the deceleration phases. In those applications in which the reverse energy is potentially large (high load inertia and / or high motor speed), it can be necessary to use a capacitor with a capacitance value much larger than the minimum value indicated above.



## NOTICES, HAZARDS AND CAUTIONS



- CSD series drives are BDM (Basic Drive Module), as defined in the EN 61800-3. They are sub-assemblies without a direct function, foreseen to be integrated in a more complex machine or installation by a professional assembler, expert in the field of motor drives and in their related problems. Only a professional assembler can install and put in service this component.
- CE marking: Products here described conform to 2006/95/CE and 2004/108/CE and further modifications, when correctly installed and used.
- They are intended to drive stepping motors with two phases, base step angle 1.8 degree and phase inductance between 1.0 and 12.0 mH. Use with different kind of motor is not allowed.
- Protection degree IP00 for CSD 02, CSD 02.V, CSD 04, CSD 04.V: use only inside a protective enclosure able to avoid electric shock hazard. Main setting, connector insertion or extraction has to be done with drive switched off.
- Protection degree IP20 for CSD 92 and CSD 94: this means that they must be located inside a protective enclosure meeting requirements of standards applicable in the specific application in which they are used. Settings and connector insertion or extraction has to be done with drive switched off. The drive generates some amount of heat. Take care of this when considering the total amount of heat generated in the enclosure in which the drives are located. In order to make easier air circulation in the drive, install the drive vertically (not turned upside down) with at least 5 cm of free space over and under the drive and 1 cm on the left and on the right of the drive. Do not obstruct air gratings.
- Installation is allowed in local environment with pollution degree N° 2 . Installation in presence of explosive and/or flammable and/or chemically aggressive and/or electrically conductive gas, vapour or dust and installation near easily flammable or heat sensitive materials is strictly forbidden.
- Use for safety related functions is forbidden (EN 60204-1); it is also forbidden any application arrangement in which a drive fault or failure could generate an hazardous condition. It is forbidden to use this material in application covered from one or more EEC directive before the conformity to those directives has been confirmed.
- Residual voltages: depending on supply type (assembled by user) and application conditions, a waiting time greater than 5 seconds after switching off could be necessary.
- Scald hazard: due to the presence of some components operating at high temperature (120°C), wait some minutes after switching off in order to avoid scalds.
- Driver could generate electromagnetic interference (both radiated and conducted) if instruction about installation directions are not respected (chap. 6). We remember however that compliance to 2004/108/CE directive has to be tested on whole machine in normal working condition and in accordance with specific standards covering the particular application.
- In case of drive failure, dangerous high voltage could appear on logic in / OUT connections. For this reason, regarding to machine safety, you have to consider that a voltage equal to  $V_{DC}$  could be present at the I/O in case of failure.
- Insulation of the drive parts is dimensioned for pollution degree N° 2 and for overvoltage class II. The drive can't be connected to the main and it has to be supplied by a power supply equipped with transformer main insulation.

## IMPORTANT NOTES

- 1)  $C \geq 10.000 \mu\text{F}$   
with  $V_{\text{DC}} \leq 30 \text{ Volt}$   
 $C \geq 4.700 \mu\text{F}$   
with  $V_{\text{DC}} > 30 \text{ Volt}$
- 2) Transformer power: from 100 to 450 VA depending on:
  - Drive model
  - Current setting
  - Motor model
  - Motor speed
  - Duty-cycle
- 3) Fuse F1: time lag with nominal current according transformer power.
- 4) Rectifier bridge: according transformer power.
- 5) Terminals 1, 8, 10, 11 and 16 are internally interconnected.
- 6) C capacitor must be near AM2 or C1 connector; max cables length = 1 m.
- 7) The maximum motor cable length is 20 meters; section according phase current RMS value.
- 8) Vac nom : from 18 to 32 Vac

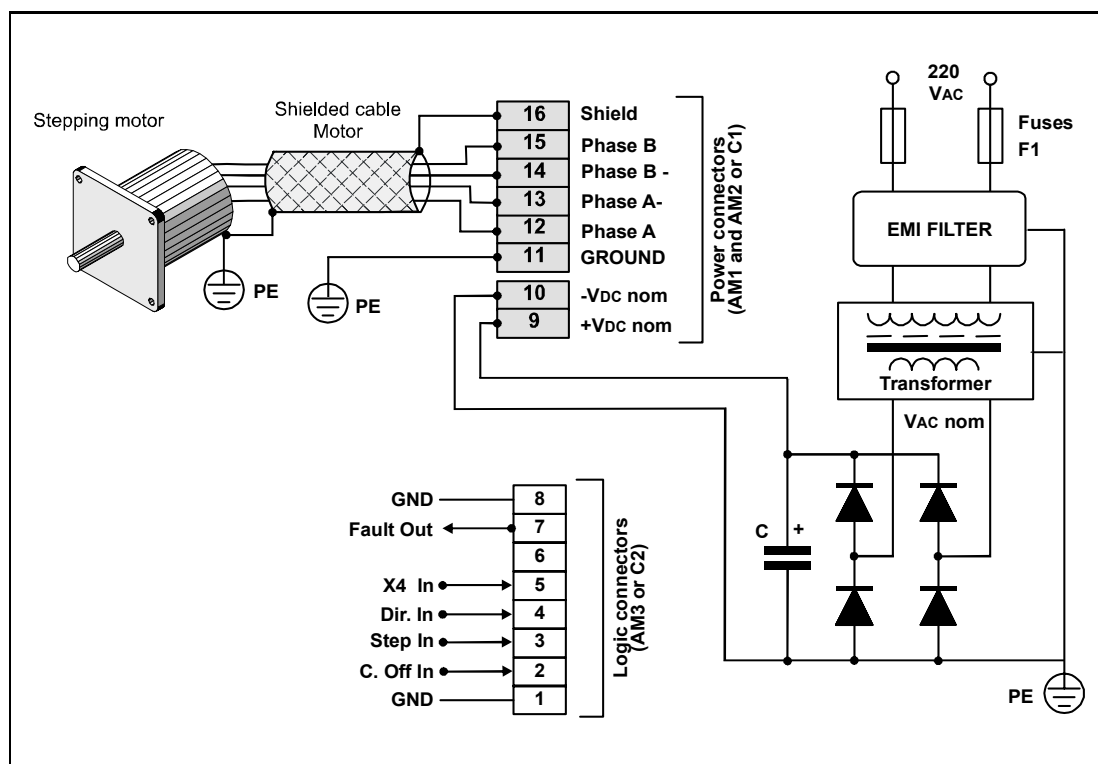

Fig. 2a - Drive external connection scheme for CSD 02, CSD 02.V, CSD 04, CSD 04.V.

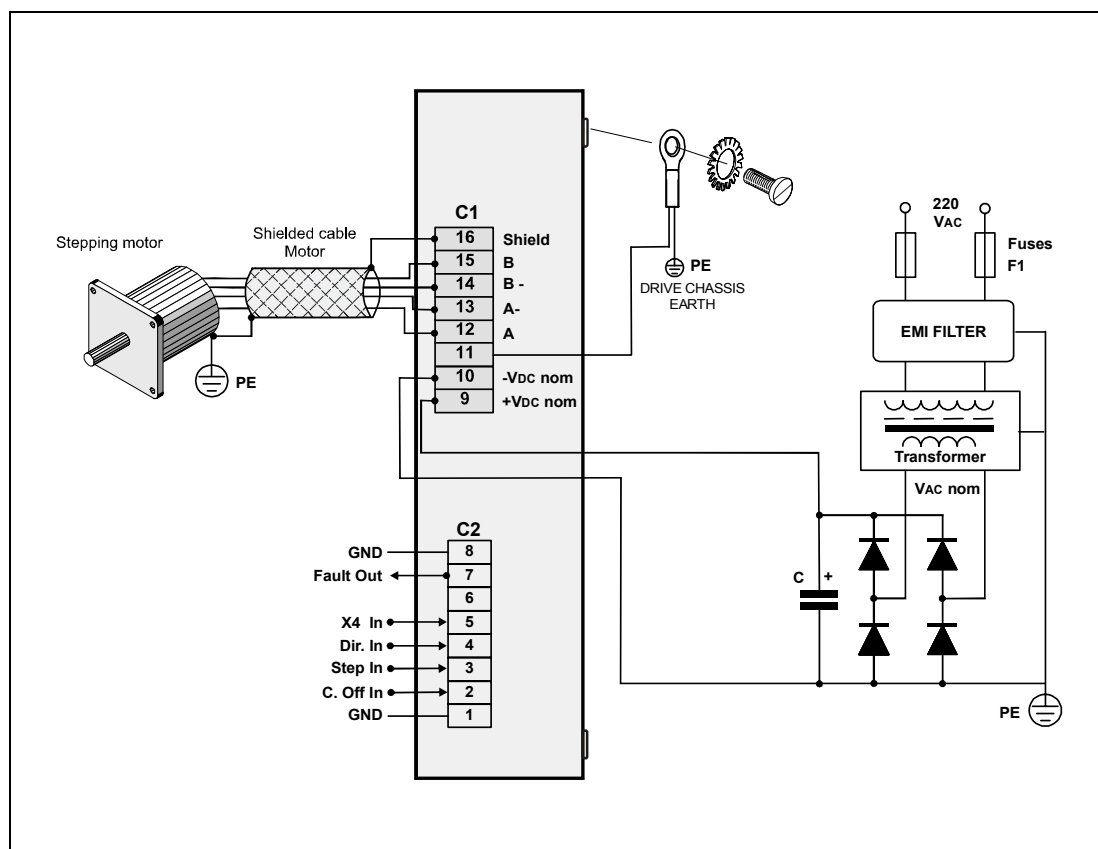

Fig. 2b - Drive external connection scheme for CSD 92 and CSD 94.

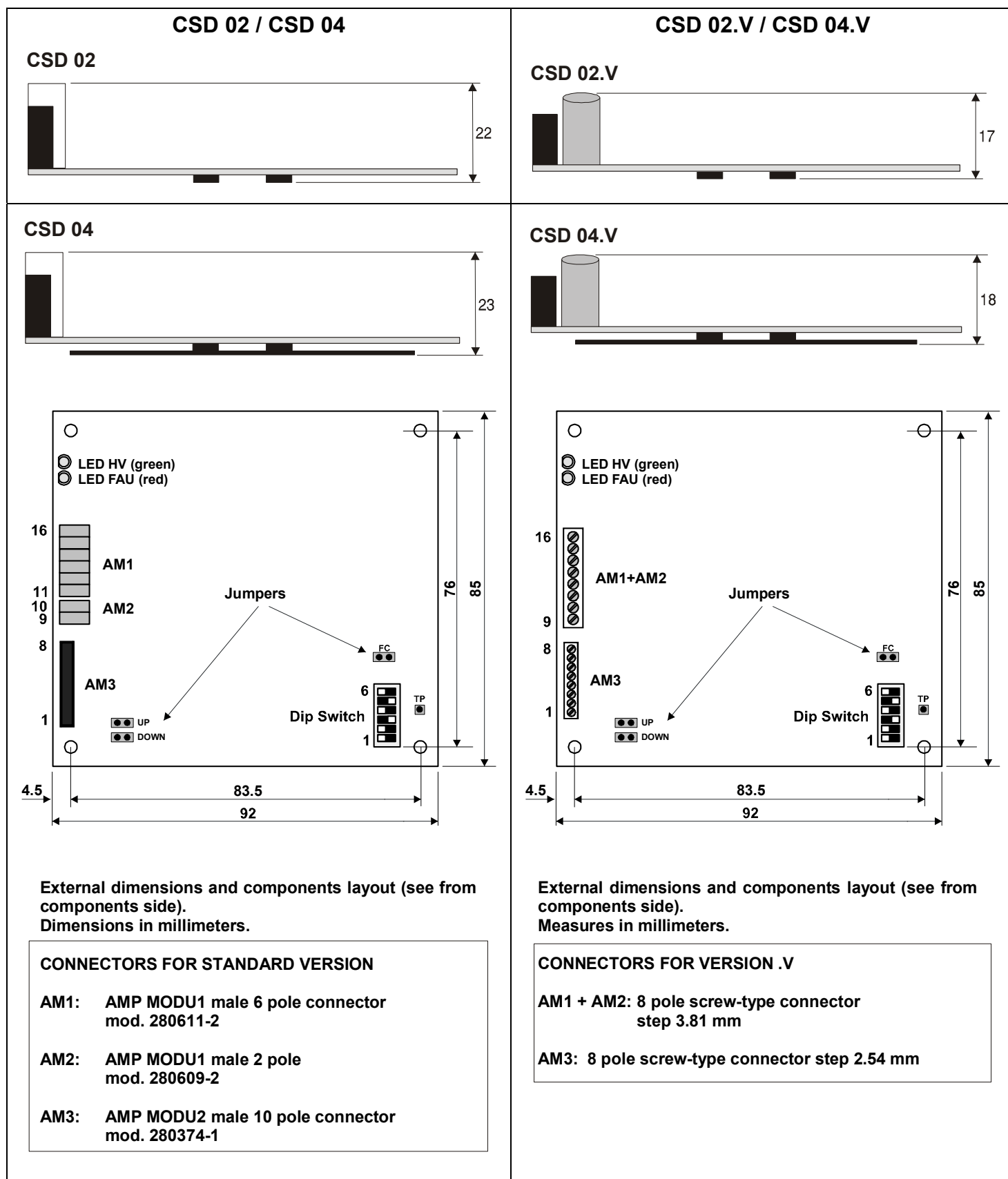

Fig. 3a

Fig. 3b

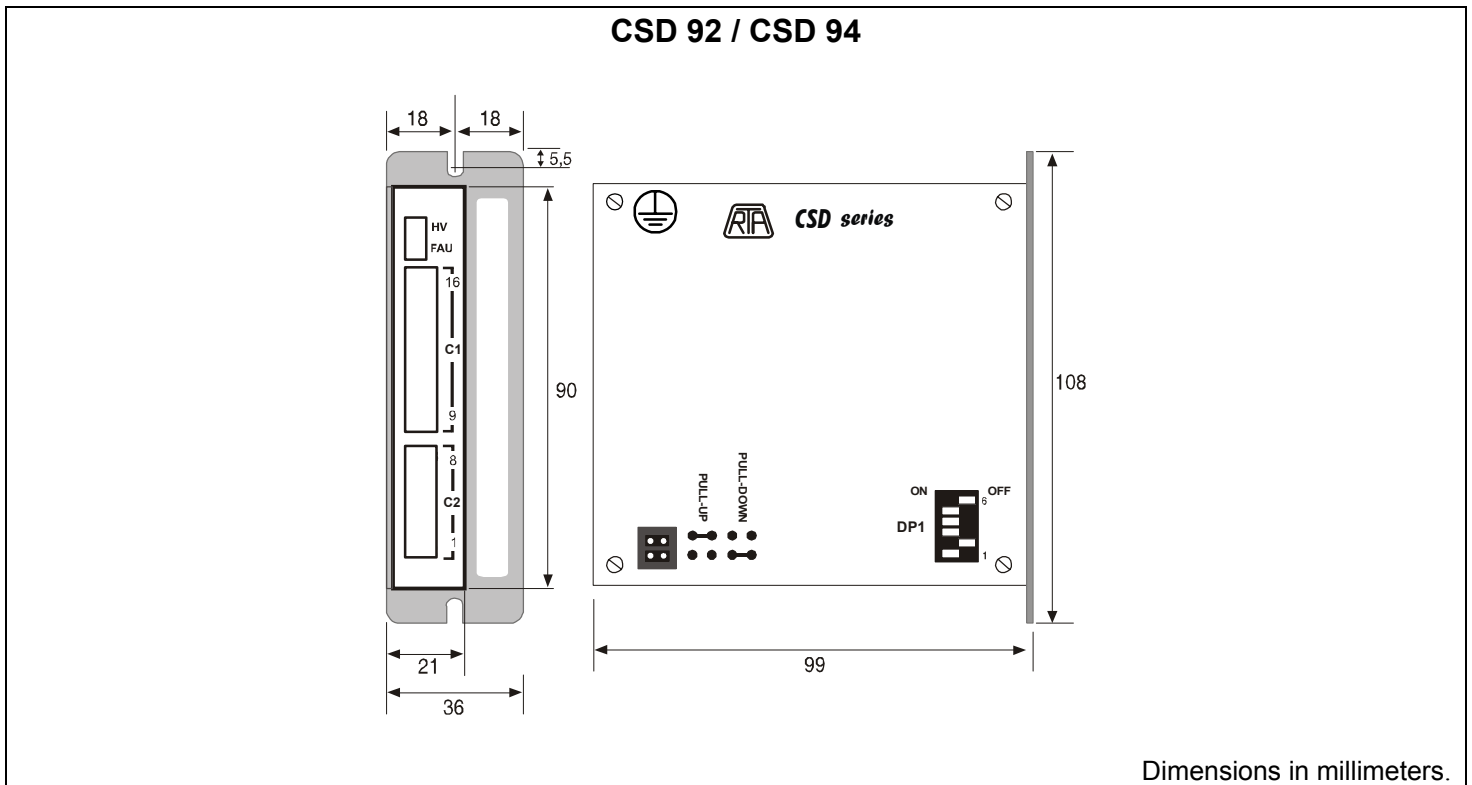

Fig. 4

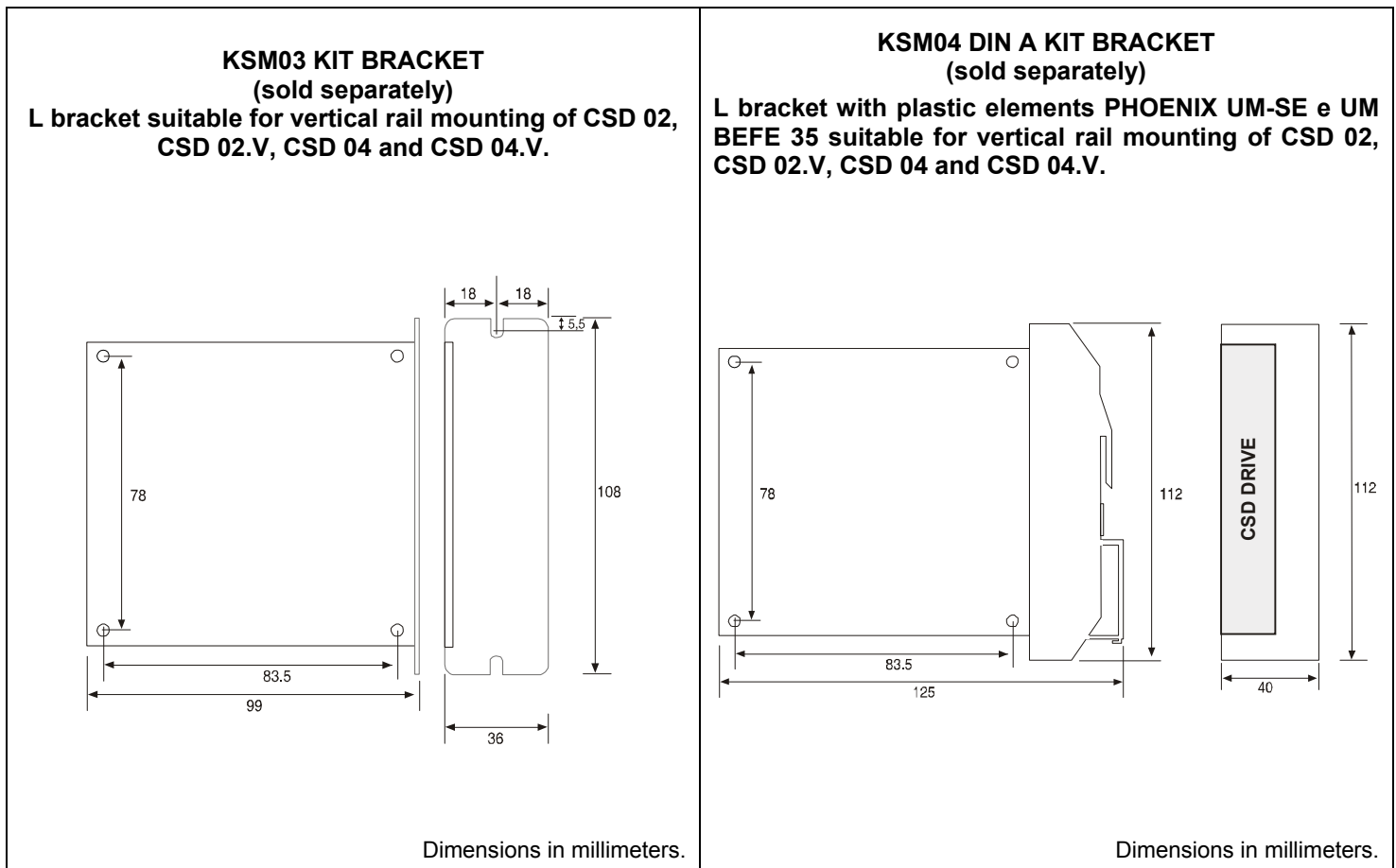

Fig. 5a

Fig. 5b